

## APPLICATION

- ▶ Suitable for interior sliding frameless glass or panels of mirror, plastic, veneered timber, etc. to showcases, bathroom cabinets, bookcases, hatches and reception windows.
- ▶ Single, double or multiple lines of panels can be arranged to suit most situations.
- ▶ Panels can be secured by a specially designed cylinder lock.

## PANEL SPECIFICATION

<b>Rail System:</b>	<b>Glassroll 25</b>
For Individual Panels:	
Max Panel Weight	25kg
Max Panel Area	1.4m <sup>2</sup>
Min Panel Width	Should not be less than half the panel height.
Panel Thickness	5mm or 6mm

The panel height is 31mm less than the opening height. The panel width, on a bi-passing application, is half the opening width plus 16mm. This provides a 38mm overlap at the centre of the opening when 506 end caps are fitted.

Panels can be of glass, mirror, plastic, veneered timber, etc., but must be either 5mm or 6mm thick to accept the appropriate glazing strip.

## STANDARD SETS

Standard sets are available for bi-passing 6mm thick panels. Sets comprise 502W top guide with woolpile, two glazing rails with 509 P.V.C. glazing strip, 505 bottom rail, four bottom rollers, four end caps, two finger pulls, all screws and installation instructions.

Set No.	Opening width
GR4	1200mm for 2 panels
GR5	1500mm for 2 panels
GR6	1800mm for 2 panels

If the panels to be used on the standard sets are 5mm thick, order the 509R uncured rubber glazing strip to replace the 509 P.V.C. 6mm glazing strip.

## HARDWARE SPECIFICATION

<b>Top Guide</b> , double run, with woolpile	502W
<b>Top Guide</b> , double run, without woolpile	502
<b>Top Guide</b> , single run, without woolpile	501
<b>Glazing Rail</b>	503
<b>Bottom Rail</b> , double run	505
<b>Bottom Rail</b> , single run	80
Material	Aluminium
Finish	Satin anodised or mill
Standard lengths	3600mm and 4500mm

**Glazing Strip:** 509  
Made from clear P.V.C. to secure a 6mm panel in the glazing rail. Available by the metre.

**Glazing Strip:** 509R  
Made from uncured rubber to secure a 5mm panel in the glazing rail. Available by the metre.

**Bottom Roller:** 504  
The nylon body incorporates a nylon wheel with a precision bearing for smooth operation. For high usage applications, or on panels from 20kg to 25kg capacity, fit two rollers close together at each end of the glazing rail.

**End Cap:** 506  
The end cap is designed to hook onto the bottom roller and is made from nylon with a satin chrome finish.

**Finger Pull:** 27  
Designed to fit into a 22mm diameter hole in the panel and is made from brass with a satin chrome finish.

**Accessories:**  
**Dust Seal:** 508  
In clear P.V.C. to fit around the vertical edge of one panel where doors overlap.

**Cylinder Lock:** 507  
Supplied with 2 keys and keyed alike or keyed to differ. Available in left or right hand. Finish – satin.

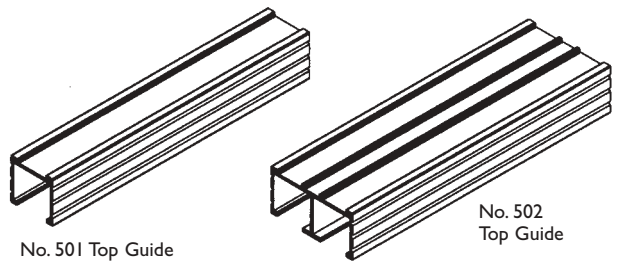
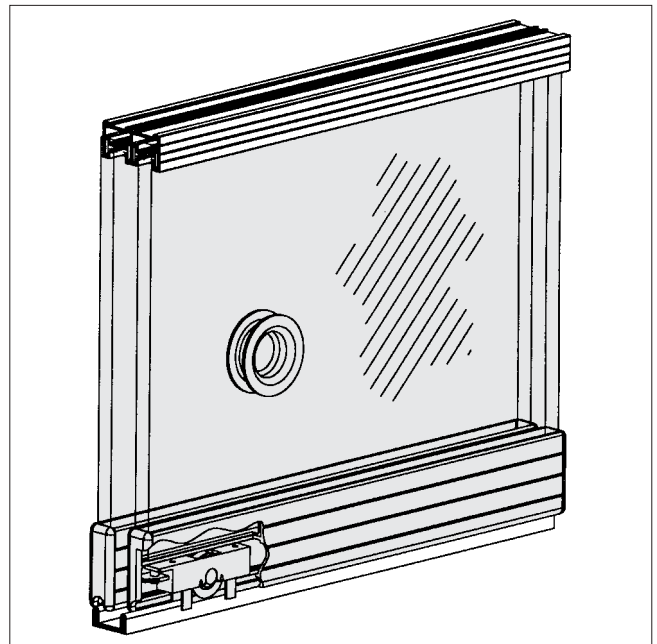

No. 501 Top Guide

No. 502 Top Guide

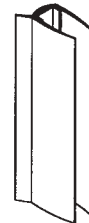

No. 508 Dust Seal

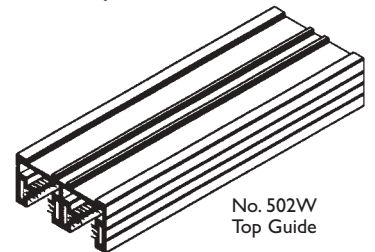

No. 502W Top Guide



No. 27 Finger Pull

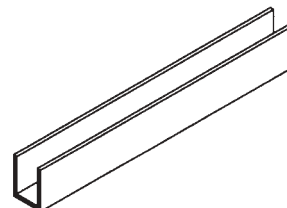

No. 509 or No. 509R Glazing Strip

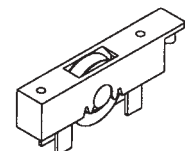

No. 504 Bottom Roller

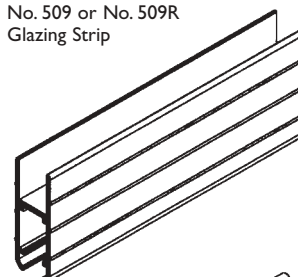

No. 503 Glazing Rail



No. 506 End Cap

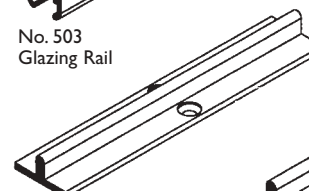

No. 80 Bottom Rail

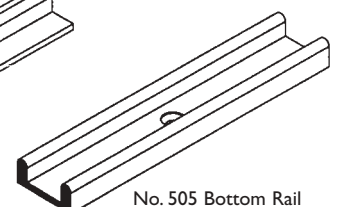

No. 505 Bottom Rail

# Glassroll 25

FOR BOTTOM ROLLER SLIDING GLASS PANELS, MAX. 25kg EACH

# HENDERSON®

SLIDING & FOLDING DOOR HARDWARE

AUSTRALIA'S WIDEST RANGE

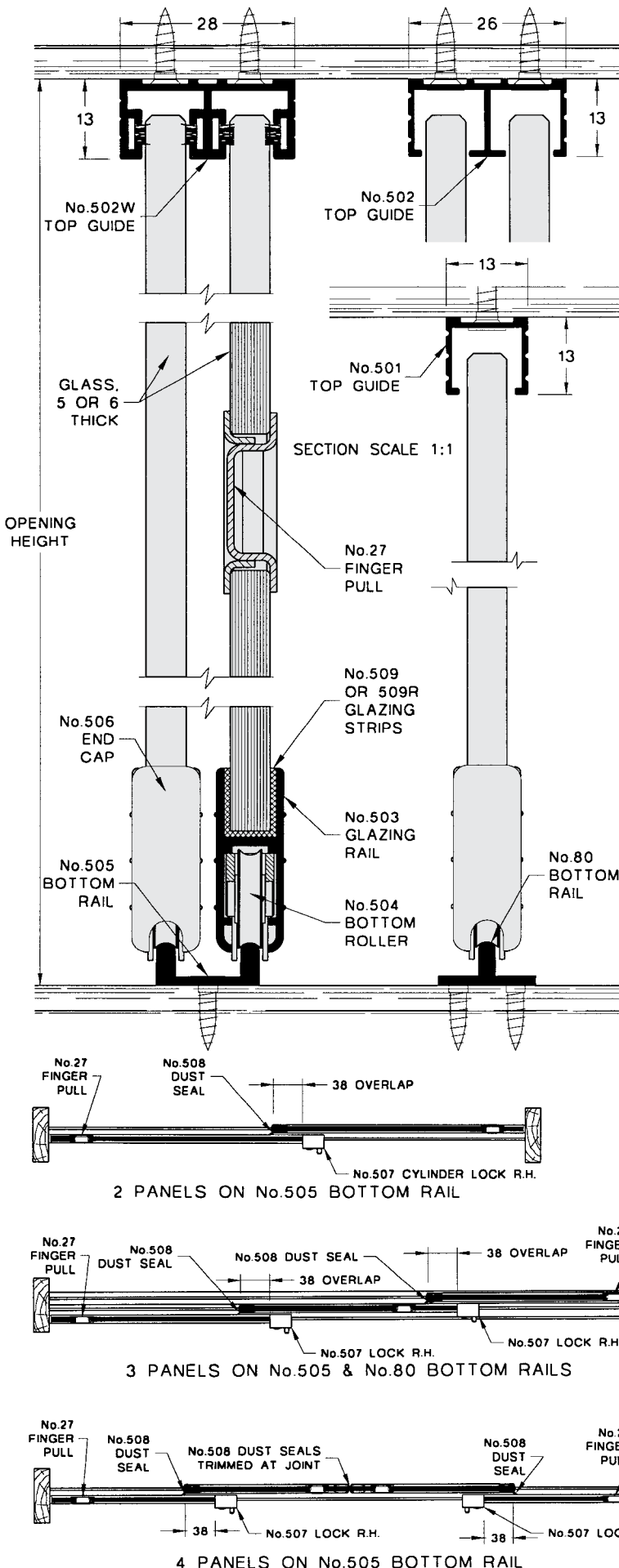

## GLASS SIZE FOR DOUBLE PASSING PANELS

Height = Opening height less 31mm.

Width = Half opening width plus 16mm.

This provides a 38mm lap at centre.

## INSTALLATION INSTRUCTIONS

- 1** Cut Bottom Rail and Top Guide to width of opening and fit in position using 12mm x 4g countersunk head wood screws.
- 2** Cut No.503 Glazing Rail to width of glass. End must be perfectly square.
- 3** Fit glass to No.503 Glazing Rail using Glazing Strip - No.509R for 5mm glass or No.509 for 6mm glass. Trim off surplus.
- 4** Insert the No.504 Bottom Rollers into ends of No.503 Glazing Rail. Hook No.506 End Caps onto pins on the Bottom Roller housing. (refer to note below, if fitting Lock.) Ensure that End Cap is hard against end of Glazing Rail. Tighten screws in roller housing.
- 5** Lift glass into Top Guide and lower onto Bottom Rail.
- 6** Fit No.27 Finger Pull in  $\phi 22$ mm hole in glass.
- 7** Cut No.508 Dust Seal to length and push onto edge of inner panel.

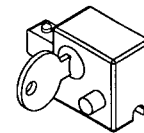

## OPTIONAL EXTRA

No.507 Cylinder Lock, - with 2 keys, Satin Finish. State hand required (R.H. illustrated). When fitted, lock replaces End Cap, refer Note 4, above. Tighten clamping screws.

Drill  $\phi 8$ mm hole in inner Glazing Rail for lock-pin, when panels are fitted. Ensure that Lock is of the correct hand and that glass overlaps by 38mm in centre.

C30B

## HENDERSON RMD

Door Hardware Division of  
RMD PRESS CO. PTY LTD.

ACN 004 313 937

© COPYRIGHT HENDERSON RMD

© HENDERSON IS A REGISTERED TRADEMARK OF PC HENDERSON LTD (UK)



SALES  
OFFICES  
IN ALL  
STATES