

APPLICATION

- ▶ Suitable for residential and light commercial folding doors.
- ▶ Ideal for use on servery hatches, appliance storage and bar areas in homes, restaurants, shops and offices.
- ▶ No bottom guide channel is necessary.

DOOR SPECIFICATION

Track System: Servery 9

For Individual Leaves:

Max Leaf Height 1200mm

Max Leaf Weight 9kg

Max Leaf Width 375mm

Min Leaf Width 150mm

Min Leaf Thickness 18mm

'Servery 9' is designed for end folding units of two, four, six or eight leaves pivoted to each side of the opening leaving a clear counter top.

Leaves should be made of equal width, allowing 1 to 2mm clearance between leaves and 6mm clearance between end leaves and jambs.

STANDARD SETS AND FITTING PACKS

Sets suitable for folding four, six or eight leaves to one side comprise – track, buffer, top socket assembly, top pivot, bottom pivot, bottom jamb bracket, hanger(s), hinges, all screws and fitting instructions.

Set No.	Opening Width
SY4	1518mm for four leaves pivoted from one side
SY6	2274mm for six leaves pivoted from one side
SY8	3030mm for eight leaves pivoted from one side

Pack No.	
1740B	Basic two leaf pack includes – bumper; top pivot assembly, top pivot, bottom pivot, jamb bracket, one hanger, two hinges, spanner, all screws and fitting instructions.

1740A	Add-on two leaf pack includes – one hanger; four hinges and all screws.
-------	---

To create your own unique application, not covered by the standard sets, select for each folding unit, one 1740B basic pack, sufficient 1740A add-on packs and a suitable length of 1740 track – see below.

HARDWARE SPECIFICATION

Track:	1740
Material	Aluminium
Standard lengths	1520mm, 2280mm, 3050mm and 4880mm
Bumper:	1713 Rubber and steel, zinc dichromate
Top Socket Assembly:	1720 Nylon and steel, zinc dichromate
Top Pivot:	1701 Steel, zinc dichromate
Bottom Pivot:	1707 Steel, zinc dichromate
Jamb Bracket:	1741 Steel, zinc dichromate
Hanger:	1742 Steel, zinc dichromate

Hanger is fitted with four nylon wheels on a nylon body. The steel top plate, zinc dichromate, includes a nylon locking slide for simple connection to the hanger.

Hinge:	1743
Hinge is a non-mortise lift-off type for ease of installation.	

Made of steel in electro brass finish.

Spanner:	812 Steel, zinc dichromate
-----------------	----------------------------

Screws for the hinges are in electro brass finish. The other screws are zinc dichromate.

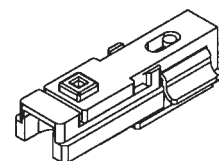
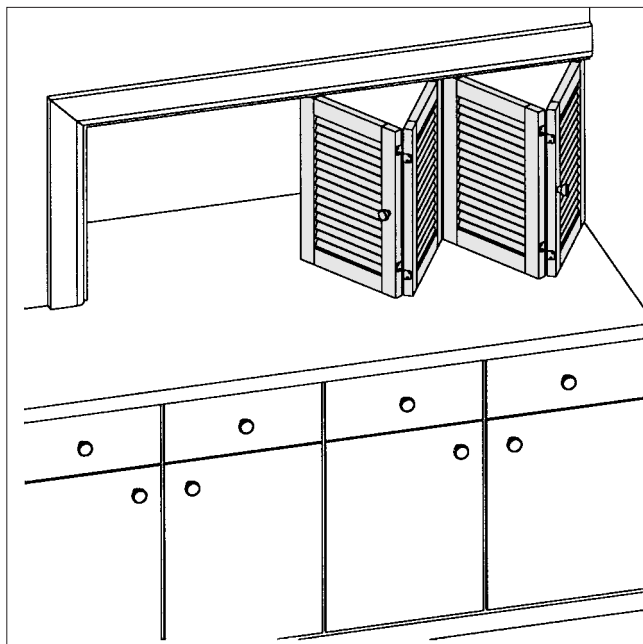

No. 1720 Top Socket Assembly

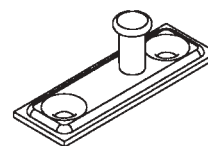

No. 1701 Top Pivot

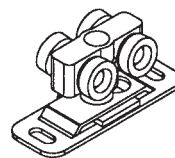

No. 1742 Hanger

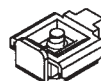

No. 1713 Bumper

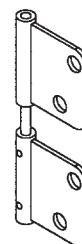

No. 1743 Hinge

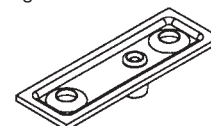

No. 1707 Bottom Pivot

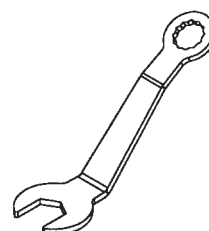

No. B12 Spanner

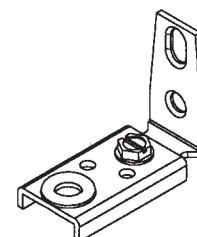

No. 1741 Jamb Bracket

Servery 9

FOR TOP HUNG INTERIOR END FOLDING COUNTER TOP DOORS, MAX. 9kg EACH LEAF

HENDERSON®

SLIDING & FOLDING DOOR HARDWARE

AUSTRALIA'S WIDEST RANGE

'SERVERY 9' is designed for end folding units of two, four, six, or eight leaves pivoted to each side of the opening leaving a clear counter top.

Leaves should be made of equal width.

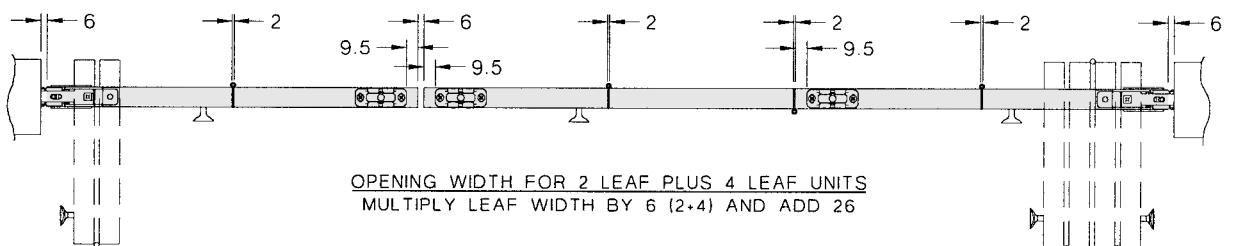
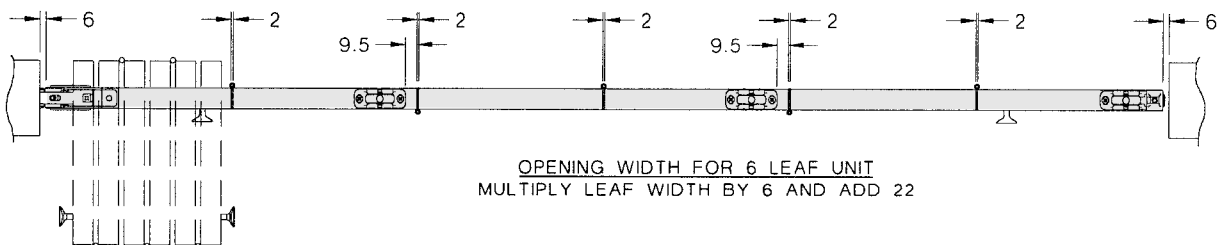
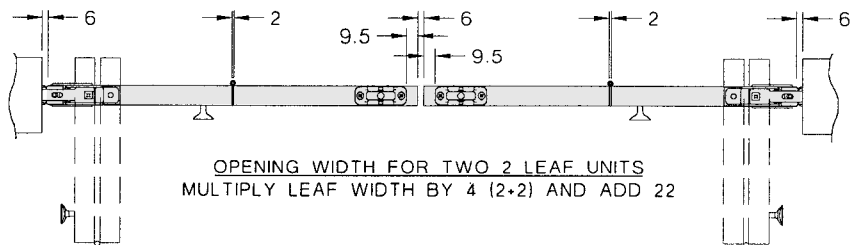
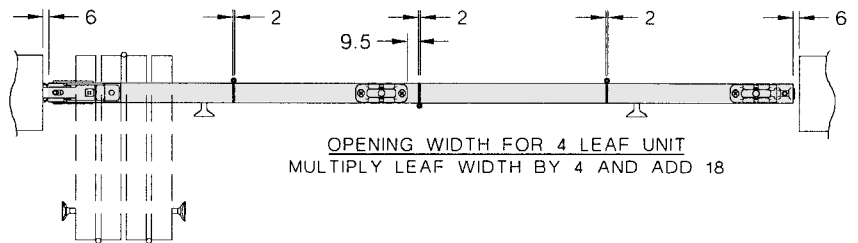
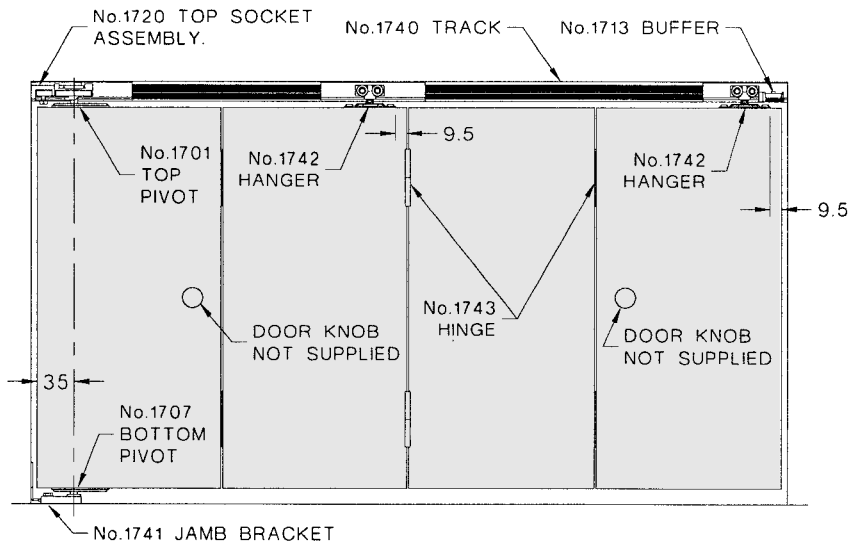
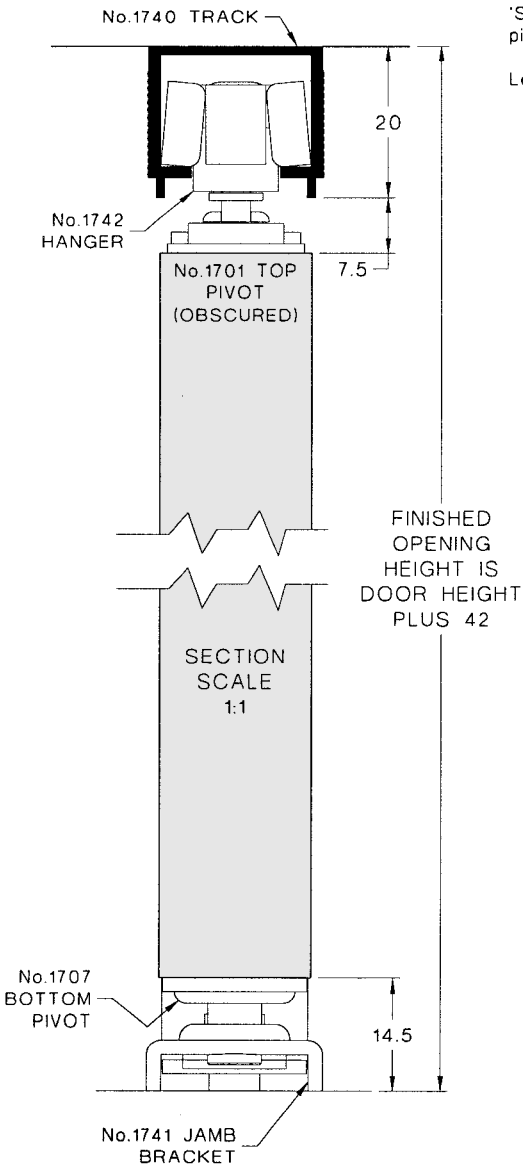

D50B

HENDERSON RMD

Door Hardware Division of
RMD PRESS CO. PTY LTD.

ACN 004 313 937

© COPYRIGHT HENDERSON RMD

© HENDERSON IS A REGISTERED TRADEMARK OF PC HENDERSON LTD (UK)



SALES OFFICES IN ALL STATES