

APPLICATION

- ▶ Suitable for interior top hung sliding doors.
- ▶ The continuous ball cage and solid runner bar provides the strength and controlled action which makes 'Marathon 90' suitable for heavy-duty residential, commercial and light industrial doors.
- ▶ Each set is suitable for a single door only, sliding twice the door width and no further. Bi-parting or bi-passing doors are possible by installation of two sets.
- ▶ The track can be either sidewall or soffit fitted by using Soffit Brackets No. 340.

DOOR SPECIFICATION

Track System: **Marathon 90**

For Individual Doors:

Max Door Weight	90kg
Max Door Width	2000mm
Min Door Width	750mm
Min Door Thickness	25mm

Suitable for all types of timber or metal framed doors. Provision must be made for secure fitting of the top plates, since the top plate has a built-in buffer which strikes the door stop.

STANDARD SETS

Sets comprise face fitted top assembly (track, ballcage, runner bar, aligners, hangers), top plates, door stops, guide(s), channel(s), all screws and installation instruction.

Set No.	Min and Max door width	Track length
S3	750mm to 900mm	1473mm
S4	900mm to 1050mm	1700mm
S5	1050mm to 1200mm	1980mm
S6	1200mm to 1500mm	2438mm
S7	1500mm to 1800mm	3048mm
S8	1800mm to 2000mm	3225mm

Do not cut the track. Each top assembly is only suitable for the door widths shown above. The design allows for each top assembly to cover the minimum and maximum travel of the door with ample vertical and lateral adjustment.

HARDWARE SPECIFICATION

Track:	Galvanised steel
Ballcage:	Galvanised steel
Runner Bar:	Steel, zinc plated

The S3 to S5 sets are supplied with one length of galvanised steel channel 93, for mortising into the bottom rail of the door and one nylon guide 102N/93 for fitting on the floor at the edge of the opening in the overlap area.

The S6 to S8 sets are supplied with two lengths of galvanised steel channel 93, for fitting into the floor, and two nylon guides 102N/93 for fitting onto the bottom rail of the door.

All components of rustless materials or rust-proofed by galvanising.

Accessories:

Soffit Bracket – Single: 340
Soffit bracket, aluminium die casting, supplied with all fastenings.

Soffit Bracket – pack of 5: 340/5
Pack of 5 Soffit Brackets 340, supplied with all fastenings, suitable for S3 to S5 sets.

Soffit Bracket – pack of 7: 340/7
Pack of 7 Soffit Brackets 340, supplied with all fastenings, suitable for S6 to S8 sets.

Simultaneous Action Unit: 23
Simultaneous Action Unit for bi-parting doors on two S3 sets - maximum overall width of both doors 1800mm.

Guide: 102WA
Guide in zinc plated steel, has lateral adjustment. Fits on the wall or architrave, in the overlap area, and slides through a 20mm deep by 5mm wide sawcut in the bottom rail of the door. Floor left free of hardware.

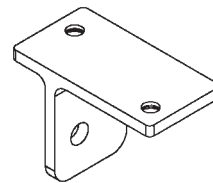
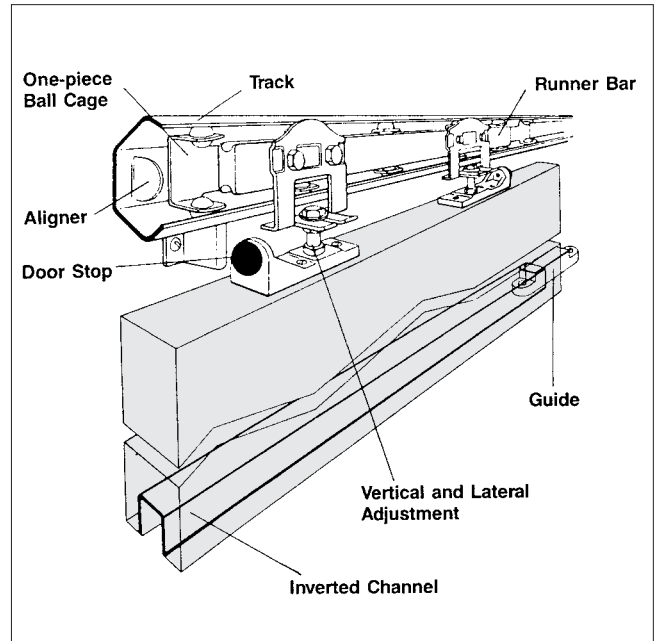

No. 340 Soffit Bracket

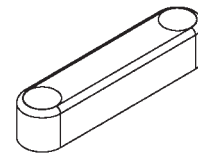

No. 102N/93 Guide

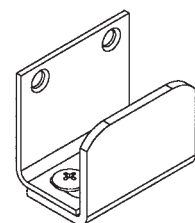

No. 102WA Guide

Marathon 90

FOR TOP HUNG SLIDING DOORS, MAX. 90kg EACH

HENDERSON®

SLIDING & FOLDING DOOR HARDWARE

AUSTRALIA'S WIDEST RANGE

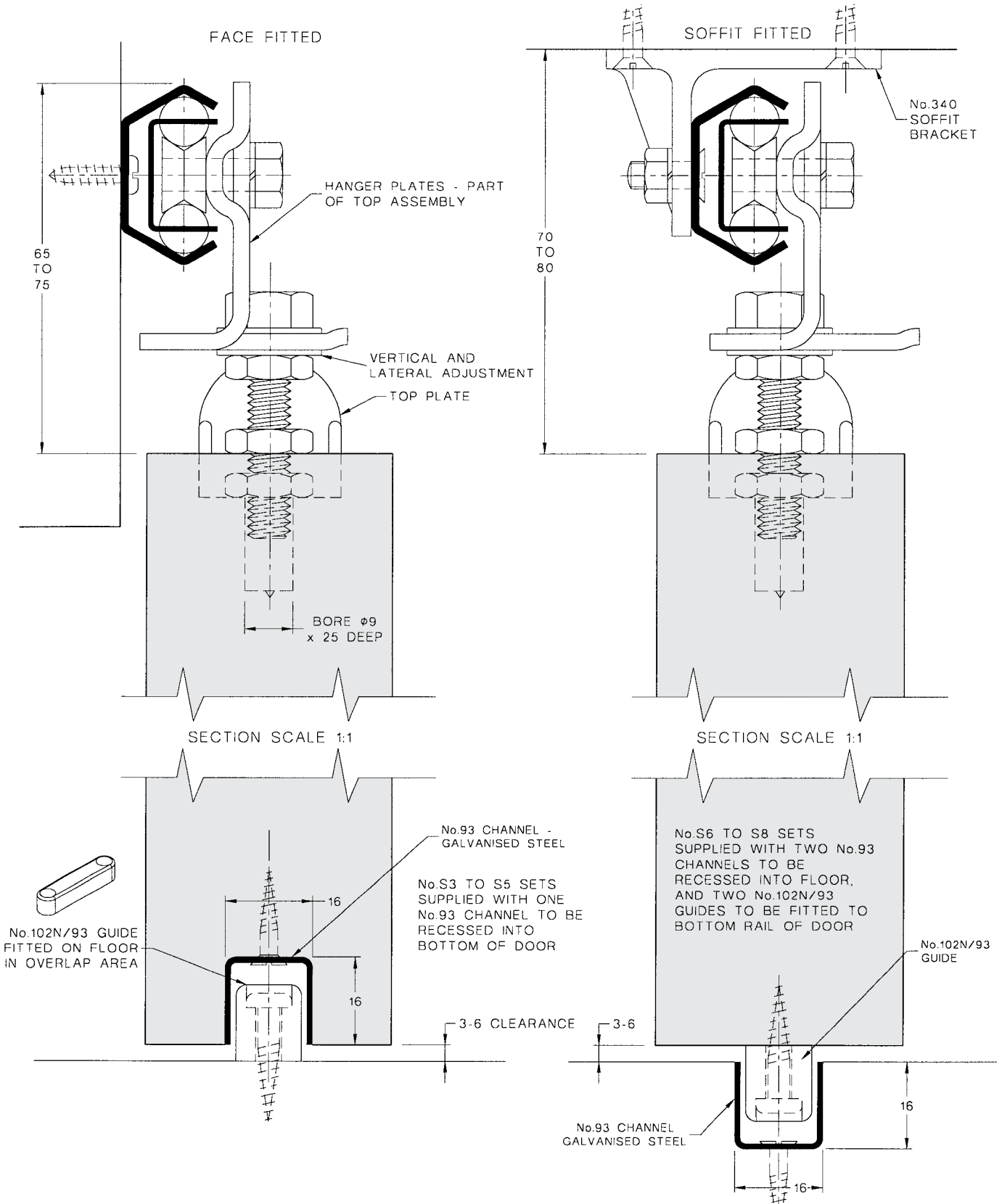

No. 23 SIMULTANEOUS ACTION UNIT for bi-parting doors, opening and closing simultaneously by a single controlled action. Maximum overall width of both doors 1800.

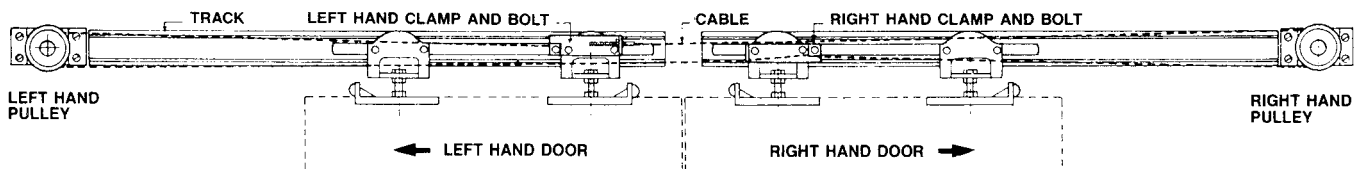

B100B

HENDERSON RMD

Door Hardware Division of
RMD PRESS CO. PTY LTD.
ACN 004 313 937

© COPYRIGHT HENDERSON RMD

© HENDERSON IS A REGISTERED TRADEMARK OF PC HENDERSON LTD (UK)

